



CAVIBLASTER®

CAVIDYNE LLC

5077 Fruitville Road
Suite 109 - 157

Sarasota, FL 34232 USA

Phone: (352) 275-5319

www.caviblast.com

Operation & Maintenance Manual



Model 1325-G

Model 1325-G OPERATING INSTRUCTIONS

WARNING: To ensure operator safety and efficient operation of the CaviBlaster[®], it is essential to follow these instructions.

Preparing the CaviBlaster system for operation:

1. Inspect the CaviBlaster[®] power unit, hoses and gun for any signs of damage.
2. Inspect inlet strainer (Figure 1) to ensure that it is not clogged. Clean if necessary.
3. Check oil and fuel levels:

Proper oil level in pressure pump (Figure 2) and engine (Figure 3).
Gasoline level in detachable fuel tank (Figure 4).



to prop
p on hea
SAE 30V



ed cap
ers' of
Oil (S

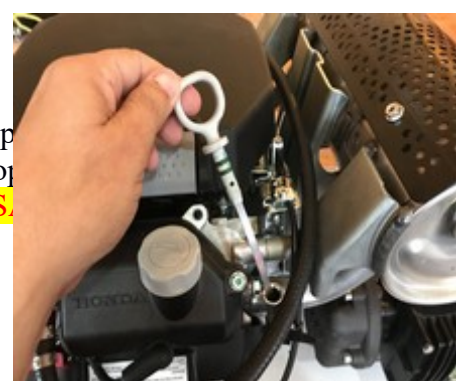

Figure 4



Figure 5



Figure 6

5. When feeding water to the CaviBlaster[®] power unit with the feed pump, connect the 1" diameter clear PVC feed hose to the cam-lock plug on the inline strainer inlet (Figure 7)

The feed hose has the feed pump on one end and a cam-lock socket on the other end (Figure 7). Insert the electrical plug powering the feed pump into the waterproof electrical outlet on the end of the power unit

cart on the handle (Figure 9). Ensure that the knob on the plug is facing up and mates with the notch in the outlet cover. If the plug is engaged upside down, the pump will turn in reverse. **Ensure that the feed hose is connected to the pressure pump, the feed pump is submerged in water, and the wiring splice is kept dry prior to starting the feed pump.** Either fresh water or seawater can be used with this system.

Note: The feed pump has had a neoprene check valve installed in the discharge. This valve will prevent water from draining out of the feed hose through the feed pump when the pump is turned off. However, this check valve somewhat restricts the flow of water from the pump. If maximum water flow is required from the feed pump, the check valve and stainless retaining washer can be removed from the pump discharge by removing the black hose barb fitting.



Figure 7

When feeding the CaviBlaster[®] with an alternate water source, **the source must supply water at a volume of greater than 13 gallons per minute at a maximum pressure of 70-psi.** Connect the water source to the inlet of the pressure pump (Figure 10). **Ensure that the feed hose is connected to the pressure pump and the water is on prior to starting the pressure pump.**



Figure 9



Figure 10

6. Connect the 1" red rubber by-pass hose to the cam-lock plug on the pressure-regulating unloader (Figure 11). The by-pass hose has a cam-lock socket on one end. Direct the bypass hose away from the working area and secure the hose.

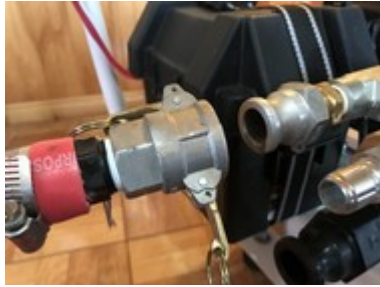

Figure 11



Figure 12

7. Connect the Dual ¼" black rubber fuel lines from the external fuel tank to the fuel lines attached to the fuel filter and engine. This connection is made with a quick connect fitting (Figure 12).

Starting the CaviBlaster[®] power unit:

1. When using the feed pump, start the feed pump by pulling the feed pump switch located on the cart handle (Figure 13) up to the "ON" position. When using a supplied water source, open the valve to supply water to the system.
2. Ensure that the system is primed with water and that there are no leaks in the system. The pressure pump is a positive displacement pump and water must be supplied under pressure.
Failure to pump feed water to the pressure pump will result in damage to the pump.
3. Once the system is primed, turn the feed pump off (Figure 13) by pushing the switch down.



Figure 13

4. Connect the ½" high-pressure hose to the quick-connect plug near the pressure-regulating unloader (Figure 14). The high-pressure hose has a brass quick-connect socket on the end. The CaviBlaster[®] 1325-G can deliver the required pressure utilizing up to 300 feet of ½" diameter rubber hose or 600 feet of thermoplastic hose. **Using greater lengths or**



Figure 14

smaller diameters of hose may degrade performance. If greater hose lengths are required, larger diameter hose must be used.

5. Connect the gun to the high pressure hose (Figure 15) and submerge the gun in water.
6. Restart the feed pump (Figure 13).
7. It is recommended that the gun trigger be in the open or “ON” position (Figure 19) when starting the engine. This will prevent a pressure shock wave from damaging the pump in the instant that the engine is started.



Figure 15

8. **Apply appropriate hearing protection prior to starting the engine.**
9. Insert the key into the ignition switch on the side of the engine (Figure 16). Pull the choke knob (Figure 17) out to close the choke if the engine is cold or has not been running. If the engine has been running and is warm, leave the choke open. Adjust the throttle lever (Figure 18) one-third of the way from “MIN” toward “MAX” for correct engine RPM. Turn the key clockwise to the “START” position. If the engine does not start within 5 seconds, release the key and wait at least 10 seconds before operating the starter again. When the engine starts, release the key, allowing it to return to the “ON” position and open the choke if it is closed.



Figure 16



Figure 17

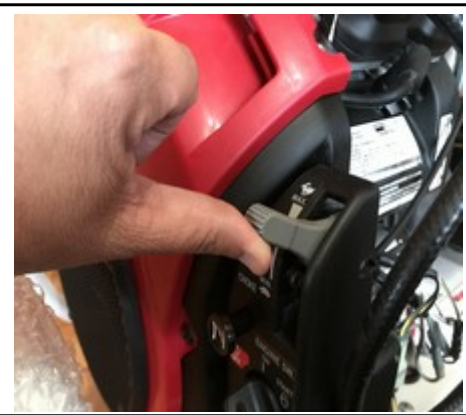

Figure 18

10. The system is now ready to operate (refer to photo on cover for overall system set-up).

Recommendations for Effective Results.

Once the engine is throttled up to operating speed and the water trigger is pulled, the diver has to find the most effective distance between the gun nozzle and the surface being cleaned.

When the diver is ready to commence cleaning operations, ensure that the gun trigger is in the open or “ON” position (See Figure 19), the gun is submerged in the water and the feed pump is operating prior to throttling up the engine. Ensure that the power unit operator and other people working in the vicinity of the power unit wear appropriate hearing protection when the engine is running.

1. Engage the pressure pump by pushing the throttle knob (See Figure 18) to the operating speed position (fully extended) to engage the centrifugal clutch.
2. The most efficient operating technique is to hold the nozzle 2-5 inches (5-12 cm) away from the surface to be cleaned and at a 25 to 45 degree angle to the surface being cleaned (See Figure 19). The diver needs to observe the shape of the cavitating jet cone. At greater depths, the higher ambient pressure will cause the jet cone to be shorter. The widest zone of the cone is the most efficient part of the cavitating jet. Placing the nozzle closer than 2 inches (5 cm) from the surface being cleaned will not allow for efficient cavitation performance and will degrade the cleaning capability of the CaviBlaster® system.
3. Follow all safety regulations that may be applicable to the work being performed.
4. If the diver operating the CaviBlaster® unit must be replaced or the cleaning operation must be terminated, disengage the pressure pump by pulling down the throttle lever into the idle position (See Figure 18) and release the water pressure remaining in the hose(s) by moving the gun trigger to the open or “ON” position while under water. Revert to step 1 of the operating instructions when the diver or replacement is ready to continue cleaning.

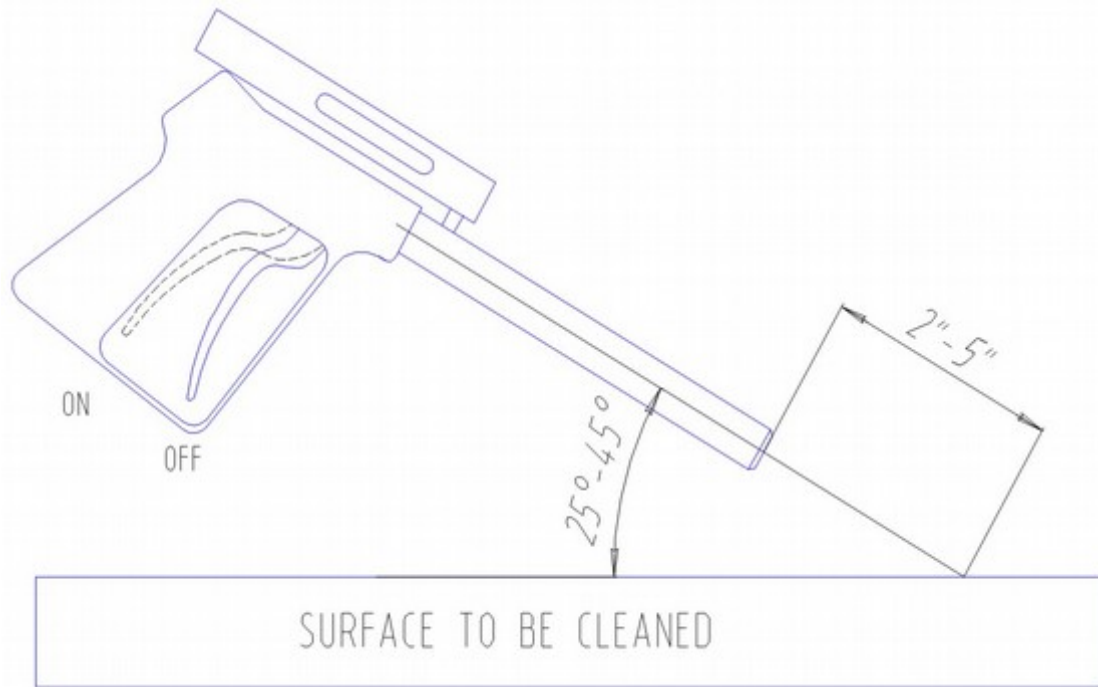

Figure 19 – Gun Position for Best Results

WARNING: Although the CaviBlaster® system is safe to use when submerged in water, the system generates a high-pressure (up to 2,500-psi) water stream, which can cause injury when the gun is out of the water. **ALWAYS** keep the gun submerged when the pressure pump is engaged.

Operating the CaviBlaster® system:

1. When the diver is ready to commence cleaning operations, ensure that the gun is submerged in water. Then move the throttle lever up to adjust the engine RPM to “MAX” (Figure 18). **Ensure that the power unit operator and other persons working in the vicinity of the power unit wear appropriate hearing protection when the engine is running.** If the diver is not wearing a helmet, hearing protection is recommended. CaviDyne™ recommends “Doc’s Proplugs” vented earplugs or equivalent for diver hearing protection.
2. Activate the cleaning cavitation stream by squeezing the trigger to the open or “ON” position (Figure 19).
3. **The most efficient operating technique is to hold the gun 2-3 inches away from the surface to be cleaned and at a 25 to 45 degree angle to the surface being cleaned (Figure 19).** Placing the gun closer than 2-3 inches from the surface being cleaned will not allow for efficient cavitation performance and will degrade the cleaning capability of the system.
4. **Wear neoprene or rubber gloves to protect the hands and follow all safety regulations that may be applicable to the work being performed.**
5. If the diver operating the unit must be replaced or the cleaning operation must be interrupted or terminated, shut down the engine by moving the throttle lever down to adjust engine RPM to “MIN” (Figure 18) and turning the key to the “OFF” position (Figure 16). Turn off the feed pump (Figure 13), **and then release the water pressure in the hose(s) by squeezing the gun trigger to the open or “ON” position (Figure 19) while under water.** Revert back to step 1 of the operating instructions when the replacement diver is ready to continue cleaning.
6. **Ensure that the gun is submerged any time the engine and pressure pump are operating.**

Adjusting the CaviBlaster® system for maximum performance:

1. If using a calibration pressure gauge situated between the pressure hose and the CaviBlaster® gun, the water pressure should be 2,500-psi with the gun submerged and the gun trigger in the open or “ON” position. The pressure is adjusted by turning the nuts on the end of the pressure-regulating unloader (Figure 20). This adjustment increases or decreases the flow of water through the bypass hose when the CaviBlaster® gun trigger is in the open or “on” position. The flow of water through the bypass hose, in turn, determines the flow of water through the pressure hose and the gun. Less flow through the bypass hose means more flow through the gun which translates to higher velocity and pressure. There should always be a trickle of water through the bypass when the gun trigger is in the open or “ON” position. This ensures that the bypass will open without a pressure shock wave damaging the pump when the gun trigger is released to the closed position.
2. If using a pressure gauge located on the CaviBlaster® power unit, the water pressure will need to be higher to account for sidewall friction loss in the pressure hose. The pressure at the pump should be 2,500-psi plus 0.75-psi per foot of pressure hose. For example, if using the CaviBlaster® with 100 feet of pressure hose, the pressure gauge located next to the pump should indicate 2,575-psi. Pressure adjustments are made in the same manner as described above. There should always be a trickle of water through the bypass when the gun trigger is in the open or “ON” position.



Figure 20

3. If adjusting the CaviBlaster® without a pressure gauge, close the pressure-regulating unloader until there is just a trickle of water (less than ¼ gallon per minute) coming out of the bypass with the gun trigger in the open or “ON” position.

Shutting down the CaviBlaster® power unit:

1. Adjust engine RPM to “MIN” (Figure 18).
2. Shut off the engine by turning the key to the “OFF” position (Figure 16).
3. Stop the feed pump by moving the feed pump switch to the “OFF” position (Figure 13).
4. Squeeze the gun trigger to the open or “ON” position (Figure 19) to release the water pressure remaining in the hose(s) while the gun is submerged.
5. It is now safe to remove the gun from the water.
6. Flush the system and rinse the power unit with fresh water at the end of the day.

Maintenance of the CaviBlaster® unit:

1. Empty and clean the inline strainer every day.
2. Check the oil level and consistency in the engine and pressure pump every day.
3. Flush the system and rinse the power unit with fresh water after each days use, **for at least 5 minutes, to make sure all inside residuals are removed.**
4. Inspect the gear box oil level, and change it after the first month or 20 hours and every six months or 100 hours thereafter.
5. Change the engine oil after the first month or 20 hours and every six months or 100 hours thereafter. Replace the oil filter every 200 hours. Use SAE 10W-30 oil for general all- temperature use.
6. Clean the air cleaner cover, filter elements and base every three months or 50 hours. Replace the paper filter element every twelve months or 300 hours or if damaged or excessively dirty.
7. Change the oil in the pressure pump after the first 50 hours and every 500 hours thereafter.
Use single-weight lubricating oil (SAE 30 weight non-detergent)
8. Change the spring for the gun trigger every 12 months or less if required.

Summarizing the operating instructions:

1. Inspect the system for damage. Clean the inlet strainer. Check oil/fuel levels.
2. Attach all hoses to the unit and connect the feed pump electrical cable.
3. Start the feed pump or alternate water supply and ensure that the system is primed.
4. Attach the gun to the pressure hose.
5. Make sure that the diver is ready to work and that the gun is submerged in the water.
6. Apply hearing protection, start the engine and adjust the throttle to "MAX."
7. Activate the cleaning cavitation stream by squeezing the gun trigger to open or "on."
8. Proceed with cleaning.
9. Stop the feed pump.
10. **Release pressure from the hose(s) by squeezing the gun trigger to the open or "ON" position while under water.**
11. Remove the gun from the water.
12. Flush the system and rinse the outside of the power unit with fresh water.

WARNING

While the CaviBlaster® system is very safe, operators should exercise care when using the equipment. The cavitation “flame” can be safely passed over the operators’ skin at normal operating distances of 2” – 3” from the tip of the nozzle. However, at very close distances (typically less than 1”) both nozzles are capable of causing harm to the operator, particularly in the initial instant that the system is activated. For that reason, **operators should exercise caution when operating the gun with the nozzles in close proximity to the body. The operators should also ensure that the reverse-thrust nozzle guard is secured in the correct position prior to operating the gun.**

The operators of the CaviBlaster® system should always wear neoprene or heavy rubber gloves to provide protection to the hands and, in particular, to the nails. The gloves will absorb most of the energy produced by bursting cavitation bubbles and prevent the cavitation bubbles from contacting the operators’ hands. The gloves will also protect operators’ hands from the initial shockwave when the gun is activated.

Serious harm and injury may result from the misuse of CaviBlaster® system equipment or improperly selected fittings, hoses or attachments. All components of the system should be checked against the manufacturers’ instructions to ensure that they are compatible with the pressures being used and of the correct thread type and pressure rating for the intended service. Refer to these Operating Instructions and to the engine and pressure pump manufacturers’ operation manuals for instructions or call CaviDyne, LLC at (352) 275-5319 with any questions.



CAUTION: DO NOT USE IT TO CLEAN SENSITIVE SURFACES as LED-Lights, Underwater Lights, Electronic Equipment, Etc.

Components

By-Pass Hose

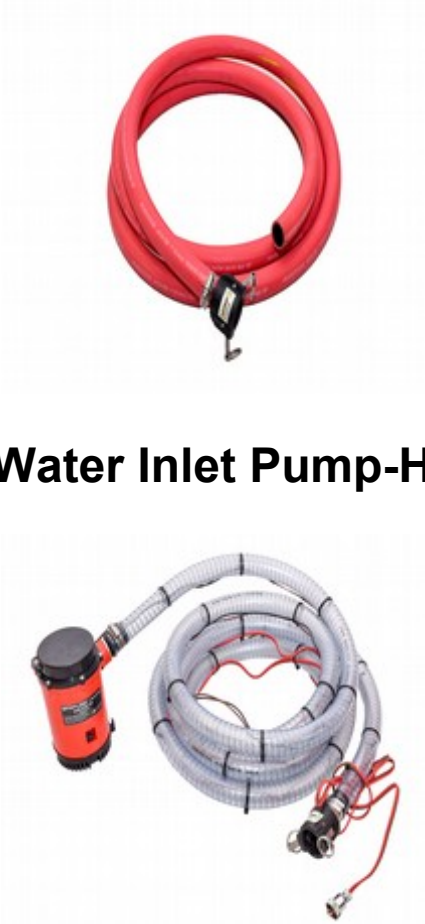

High Pressure Hose



Water Inlet Pump-Hose



Zero Thrust Gun



High Pressure Lance



Gasoline Tank

